

Infrared Transceiver Module (SIR, 115.2 kbit/s) for IrDA® Applications

Description

The TFDU4101 transceiver is an infrared transceiver module compliant to the latest IrDA physical layer standard for fast infrared data communication, supporting IrDA speeds up to 115.2 kbit/s (SIR), and carrier based remote control modes. Integrated within the transceiver module are a photo pin diode, an infrared emitter (IRED), and a low-power control IC to provide a total front-end solution in a single package. This device covers the full IrDA range of more than 1 m using the internal intensity control. With one external current control resistor the current can be adjusted for shorter ranges saving operating current operating in IrDA low power mode. This Vishay SIR transceiver is using the lead frame technology. The receiver output pulse duration is independent of



the optical input pulse duration and recovers always a fixed pulse duration optimum for compatibility to standard Endecs and interfaces. TFDU4101 has a tri-state output and is floating in shutdown mode with a weak pull-up.

Features

- Operates from 2.4 V to 5.5 V within specification over full temperature range from - 30 °C to + 85 °C
- Split power supply, transmitter and receiver can be operated from two power supplies with relaxed requirements saving costs, US - Patent No. 6,157,476
- Low power consumption (< 0.12 mA supply current in receive mode, no signal)
- Power shutdown mode (< 4 µA shutdown current in full temperature range, up to 85 °C, < 10 nA at 25 °C)
- Surface mount 4-mm package
L 9.7 mm × W 4.7 mm × H 4.0 mm



- High efficiency emitter
- Low profile (universal) package capable of surface mount soldering to side and top view orientation
- Directly Interfaces with various super I/O and controller devices as e. g. TOIM4232
- Tri-state-receiver output, floating in shut down with a weak pull-up
- Lead (Pb)-free device
- Qualified for lead (Pb)-free and Sn/Pb processing (MSL4)
- Device in accordance with RoHS 2002/95/EC and WEEE 2002/96EC

Applications

- Printers, fax machines, photocopiers, screen projectors
- Internet TV boxes, video conferencing systems
- Medical data collection
- Diagnostic systems
- Notebook computers, desktop PCs, palmtop computers (Win CE, Palm PC), PDAs
- Internet TV boxes, video conferencing systems
- External infrared adapters (dongles)
- Data loggers
- GPS
- Kiosks, POS, point and pay devices
- Industrial applications

Parts Table

| Part | Description | Qty/reel |
|--------------|---|----------|
| TFDU4101-TR3 | Oriented in carrier tape for side view surface mounting | 1000 pcs |
| TFDU4101-TT3 | Oriented in carrier tape for top view surface mounting | 1000 pcs |

Functional Block Diagram

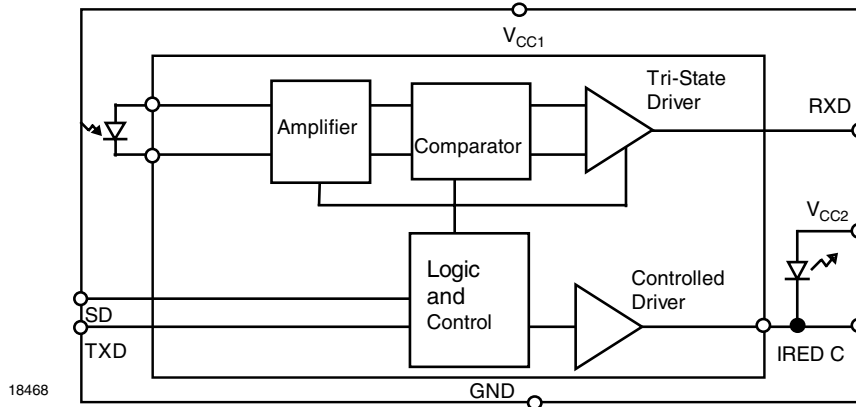

Pin Description

| Pin number | Function | Description | I/O | Active |
|------------|--------------------------------|--|-----|--------|
| 1 | V _{CC2} IRED Anode | IRED anode to be externally connected to V _{CC2} . An external resistor is only necessary for controlling the IRED current when a current reduction below 300 mA is intended to operate in IrDA low power mode. This pin is allowed to be supplied from an uncontrolled power supply separated from the controlled V _{CC1} - supply. | | |
| 2 | IRED Cathode | IRED cathode, internally connected to driver transistor | | |
| 3 | TXD | This Schmitt-Trigger input is used to transmit serial data when SD is low. An on-chip protection circuit disables the LED driver if the TXD pin is asserted for longer than 50 μs (max 300 μs). | I | High |
| 4 | RXD | Received Data Output, push-pull CMOS driver output capable of driving standard CMOS or TTL loads. During transmission the RXD output is active (echo-on). No external pull-up or pull-down resistor is required. Floating with a weak pull-up of 500 kΩ (typ.) in shutdown mode. | O | Low |
| 5 | SD | Shutdown | I | High |
| 6 | V _{CC1} | Supply Voltage | | |
| 7 | NC | No internal connection | I | |
| 8 | GND | Ground | | |

Pinout

TFDU4101
weight 200 mg

"U" Option BabyFace (Universal)

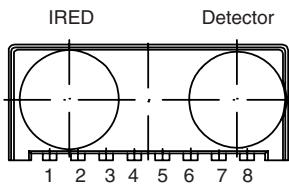

17087



Absolute Maximum Ratings

Reference point pin, GND unless otherwise noted.

Typical values are for DESIGN AID ONLY, not guaranteed nor subject to production testing.

| Parameter | Test conditions | Symbol | Min. | Typ. | Max. | Unit |
|---|--|-----------------|------|------|-----------------|------|
| Supply voltage range, transceiver | $-0.3\text{ V} < V_{CC2} < 6.0\text{ V}$ | V_{CC1} | -0.5 | | 6.0 | V |
| Supply voltage range, transmitter | $-0.5\text{ V} < V_{CC1} < 6.0\text{ V}$ | V_{CC2} | -0.5 | | 6.0 | V |
| Voltage at RXD | $-0.5\text{ V} < V_{CC1} < 6.0\text{ V}$ | V_{RXD} | -0.5 | | $V_{CC1} + 0.5$ | V |
| Voltage at all inputs and outputs | $V_{in} > V_{CC1}$ is allowed | V_{in} | -0.5 | | 6.0 | V |
| Input currents | For all pins, except IRED anode pin | | | | 10 | mA |
| Output sinking current | | | | | 25 | mA |
| Power dissipation | See derating curve | P_D | | | 250 | mW |
| Junction temperature | | T_J | | | 125 | °C |
| Ambient temperature range (operating) | | T_{amb} | -30 | | +85 | °C |
| Storage temperature range | | T_{stg} | -30 | | +85 | °C |
| Soldering temperature | See "Recommended Solder Profile" | | | | 260 | °C |
| Average output current, pin 1 | | $I_{IRED} (DC)$ | | | 80 | mA |
| Repetitive pulse output current, pin 1 to pin 2 | $< 90\ \mu\text{s}, t_{on} < 20\ %$ | $I_{IRED} (RP)$ | | | 400 | mA |

Eye safety information

Reference point pin: GND unless otherwise noted.

Typical values are for DESIGN AID ONLY, not guaranteed nor subject to production testing.

| Parameter | Test conditions | Symbol | Min. | Typ. | Max. | Unit |
|-------------------------------|---|--------|------|------|---------------------------------------|-------|
| Virtual source size | Method: EN ISO 11146 | d | 2.6 | | | mm |
| Maximum Intensity for Class 1 | IEC60825-1 or EN60825-1, edition Jan. 2001 operating below the absolute maximum ratings | I_e | | | ^{*)} (500) ^{**)} | mW/sr |

Notes:

^{*)} Due to the internal limitation measures the device is a "class1" device under all conditions

^{**)} IrDA specifies the max. intensity with 500 mW/sr

Definitions:

In the Vishay transceiver data sheets the following nomenclature is used for defining the IrDA operating modes:

SIR: 2.4 kbit/s to 115.2 kbit/s, equivalent to the basic serial infrared standard with the physical layer version IrPhy: 1.0

MIR: 576 kbit/s to 1152 kbit/s

FIR: 4 Mbit/s

VFIR: 16 Mbit/s

MIR and FIR were implemented with the physical layer standard IrPhy 1.1, followed by IrPhy 1.2, adding the SIR low power standard. IrPhy 1.3 extended the low power option to MIR and FIR and VFIR was added with IrPhy 1.4. A new version of the standard in any case obsoletes the former version.

Note: We apologize to use sometimes in our documentation the abbreviation LED and the word light emitting diode instead of infrared emitting diode (IRED) for IR-emitters. That is by definition wrong; we are here following just a bad trend.

Typical values are for design aid only, not guaranteed nor subject to production testing and may vary with time.

Electrical Characteristics

Transceiver

$T_{amb} = 25\text{ }^{\circ}\text{C}$, $V_{CC1} = V_{CC2} = 2.4\text{ V to } 5.5\text{ V}$ unless otherwise noted.

Typical values are for DESIGN AID ONLY, not guaranteed nor subject to production testing.

| Parameter | Test conditions/pins | Symbol | Min. | Typ. | Max. | Unit |
|---|---|-----------|----------------------|------|-----------------------|--------------------|
| Supply voltage | | V_{CC1} | 2.4 | | 5.5 | V |
| Dynamic supply current | SD = Low, $E_e = 1\text{ klx}^{\wedge}$, $T_{amb} = -25\text{ }^{\circ}\text{C to } +85\text{ }^{\circ}\text{C}$ $V_{CC1} = V_{CC2} = 2.4\text{ V to } 5.5\text{ V}$ | I_{CC1} | | 90 | 130 | μA |
| Dynamic supply current | SD = Low, $E_e = 1\text{ klx}^{\wedge}$, $T_{amb} = 25\text{ }^{\circ}\text{C}$ $V_{CC1} = V_{CC2} = 2.4\text{ V to } 5.5\text{ V}$ | I_{CC1} | | 75 | | μA |
| Average dynamic supply current, transmitting | $I_{IRED} = 300\text{ mA}$, 25 % Duty Cycle | I_{CC} | | | 0.65 | mA |
| Shutdown supply current | SD = High, $T = 25\text{ }^{\circ}\text{C}$, $E_e = 0\text{ klx}$ No signal, no resistive load | I_{SD} | | | 0.1 | μA |
| | SD = High, $T = 70\text{ }^{\circ}\text{C}$ No signal, no resistive load | I_{SD} | | | 3 | μA |
| | SD = High, $T = 85\text{ }^{\circ}\text{C}$ No signal, no resistive load | I_{SD} | | | 4 | μA |
| Operating temperature range | | T_A | -30 | | +85 | $^{\circ}\text{C}$ |
| Output voltage Low, RXD | $C_{load} = 15\text{ pF}$ | V_{OL} | -0.5 | | $0.15 \times V_{CC1}$ | V |
| Output voltage High, RXD | $I_{OH} = -500\text{ }\mu\text{A}$, $C_{Load} = 15\text{ pF}$ | V_{OH} | $0.8 \times V_{CC1}$ | | $V_{CC1} + 0.5$ | V |
| | $I_{OH} = -250\text{ }\mu\text{A}$, $C_{Load} = 15\text{ pF}$ | V_{OH} | $0.9 \times V_{CC1}$ | | $V_{CC1} + 0.5$ | V |
| RXD to V_{CC1} impedance | | R_{RXD} | 400 | 500 | 600 | $\text{k}\Omega$ |
| Input voltage low (TXD, SD) | | V_{IL} | -0.5 | | 0.5 | V |
| Input voltage High (TXD, SD) | $1.5\text{ V} \leq V_{logic} \leq 2.5\text{ V}^{**}$) | V_{IH} | $0.8 \times V_{CC1}$ | | 6 | V |
| | $V_{logic} > 2.5\text{ V}^{**}$) | V_{IH} | $V_{CC1} - 0.5$ | | 6 | V |
| Input leakage current (TXD, SD) | $V_{in} = 0.9 \times V_{CC1}$ | I_{ICH} | -2 | | +2 | μA |
| Controlled pull down current $0 < V_{in} < 0.15 V_{CC1}$ $V_{in} > 0.7 V_{CC1}$ | SD, TXD = "0" or "1" | I_{ITX} | | | +150 | μA |
| | | | -1 | 0 | 1 | μA |
| Input capacitance (TXD, SD) | | C_I | | | 5 | pF |

^{\wedge}) Standard Illuminant A

^{**}) The typical threshold level is $0.5 \times V_{CC1}$. It is recommended to use the specified min./max. values to avoid increased operating current.



Optoelectronic Characteristics

Receiver

$T_{amb} = 25\text{ }^{\circ}\text{C}$, $V_{CC1} = V_{CC2} = 2.4\text{ V}$ to 5.5 V unless otherwise noted.

Typical values are for DESIGN AID ONLY, not guaranteed nor subject to production testing.

| Parameter | Test conditions | Symbol | Min. | Typ. | Max. | Unit |
|---|---|----------------------|------------|-----------|---------------|---|
| Minimum irradiance E_e in angular range**) SIR mode | 9.6 kbit/s to 115.2 kbit/s $\lambda = 850\text{ nm}$ to 900 nm ; $\alpha = 0^{\circ}, 15^{\circ}$ | $E_{e, \text{min.}}$ | 4 (0.4) | 20 (2) | 35*) (3.5) | mW/m^2 ($\mu\text{W}/\text{cm}^2$) |
| Maximum irradiance E_e in angular range | $\lambda = 850\text{ nm}$ to 900 nm | $E_{e, \text{max.}}$ | 5 (500) | | | kW/m^2 (mW/cm^2) |
| Rise time of output signal | 10 % to 90 %, $C_L = 15\text{ pF}$ | $t_{r(\text{RXD})}$ | 20 | | 100 | ns |
| Fall time of output signal | 90 % to 10 %, $C_L = 15\text{ pF}$ | $t_{f(\text{RXD})}$ | 20 | | 100 | ns |
| RXD pulse width | input pulse length $> 1.2\text{ }\mu\text{s}$ | t_{PW} | 1.65 | 2.2 | 3.0 | μs |
| Leading edge jitter | Input Irradiance = $100\text{ mW}/\text{m}^2$, $\leq 115.2\text{ kbit/s}$ | | | | 250 | ns |
| Standby/shutdown delay, receiver startup time | After shutdown active or power-on | | | | 500 | μs |
| Latency | | t_L | | 100 | 150 | μs |

Notes:

*) IrDA specification is $40\text{ mW}/\text{m}^2$. Specification takes a window loss of 10 % into account.

) IrDA sensitivity definition: **Minimum irradiance E_e in angular range, power per unit area. The receiver must meet the BER specification while the source is operating at the minimum intensity in angular range into the minimum half-angle range at the maximum link length

***) **Maximum irradiance E_e in angular range**, power per unit area. The optical power delivered to the detector by a source operating at the maximum intensity in angular range at minimum link length must not cause receiver overdrive distortion and possible related link errors. If placed at the Active Output Interface reference plane of the transmitter, the receiver must meet its bit error ratio (BER) specification.

For more definitions see the document "Symbols and Terminology" on the Vishay Website (<http://www.vishay.com/docs/82512/82512.pdf>).

Optoelectronic Characteristics, continued

Transmitter

$T_{amb} = 25\text{ }^{\circ}\text{C}$, $V_{CC1} = V_{CC2} = 2.4\text{ V}$ to 5.5 V unless otherwise noted.

Typical values are for DESIGN AID ONLY, not guaranteed nor subject to production testing.

| Parameter | Test conditions | Symbol | Min. | Typ. | Max. | Unit |
|---|---|----------------------------|---------------------|----------|---------------------|---------------|
| IRED operating current, switched current limiter | No external resistor for current limitation ^{*)} | I_D | 250 | 300 | 350 | mA |
| Forward voltage of built-in IRED | $I_f = 300\text{ mA}$ | V_f | 1.4 | 1.8 | 1.9 | V |
| Output leakage IRED current | | I_{IRED} | - 1 | | 1 | μA |
| Output radiant intensity | $\alpha = 0^{\circ}, 15^{\circ}$ TXD = High, SD = Low | I_e | 48 | 65 | | mW/sr |
| Output radiant intensity | $V_{CC1} = 5.0\text{ V}$, $\alpha = 0^{\circ}, 15^{\circ}$ TXD = Low or SD = High (Receiver is inactive as long as SD = High) | I_e | | | 0.04 | mW/sr |
| Output radiant intensity, angle of half intensity | | α | | ± 24 | | deg |
| Peak - emission wavelength ^{**)} | | λ_p | 880 | | 900 | nm |
| Spectral bandwidth | | $\Delta\lambda$ | | 45 | | nm |
| Optical rise time, Optical fall time | | t_{ropt} , t_{fopt} | 10 | | 300 | ns |
| Optical output pulse duration | input pulse width $1.6\text{ }\mu\text{s} < t_{TXD} < 20\text{ }\mu\text{s}$ | t_{opt} | t_{TXD} - 0.15 | | t_{TXD} + 0.15 | μs |
| Optical output pulse duration | input pulse width $t_{TXD} \geq 20\text{ }\mu\text{s}$ | t_{opt} | | 20 | 300 | μs |
| Optical overshoot | | | | | 25 | % |

Notes:

^{*)} Using an external current limiting resistor is allowed and recommended to reduce IRED intensity and operating current when current reduction is intended to operate at the IrDA low power conditions.

E.g. for $V_{CC2} = 3.3\text{ V}$ a current limiting resistor of $R_s = 56\text{ }\Omega$ will allow a power minimized operation at IrDA low power conditions.

^{**)} Due to this wavelength restriction compared to the IrDA spec of 850 nm to 900 nm the transmitter is able to operate as source for the standard remote control applications with codes as e. g. Philips RC5/RC6[®] or RECS 80.

Recommended Circuit Diagram

Operated with a clean low impedance power supply the TFDU4101 needs no additional external components. However, depending on the entire system design and board layout, additional components may be required (see figure 1). That is especially the case when separate power supplies are used for bench tests. When using compact wiring and regulated supplies as e. g. in phone applications in most cases no external components are necessary.

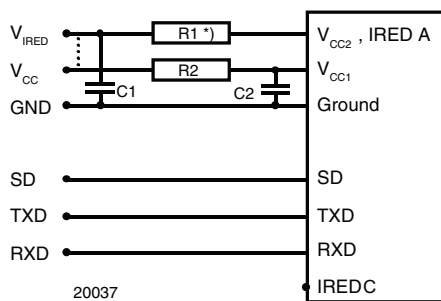

Figure 1. Recommended Test Circuit.

*) R1 is optional when reduced intensity is used.

The capacitor C1 is buffering the supply voltage and eliminates the inductance of the power supply line. This one should be a Tantalum or other fast capacitor to guarantee the fast rise time of the IRED current. The resistor R1 is the current limiting resistor, which may be used to reduce the operating current to levels below the specified controlled values for saving battery power.

VISHAY's transceivers integrate a sensitive receiver and a built-in power driver. The combination of both needs a careful circuit board layout. The use of thin, long, resistive and inductive wiring should be avoided. The shutdown input must be grounded for normal operation, also when the shutdown function is not used.

The inputs (TXD, SD) and the output RXD should be directly connected (DC - coupled) to the I/O circuit. The capacitor C2 combined with the resistor R2 is the low pass filter for smoothing the supply voltage. R2, C1 and C2 are optional and dependent on the quality of the supply voltages V_{CC1} and injected noise. An unstable power supply with dropping voltage during transmission may reduce the sensitivity (and transmission range) of the transceiver.

The placement of these parts is critical. It is strongly recommended to position C2 as close as possible to the transceiver power supply pins.

When extended wiring is used (bench tests!) the inductance of the power supply can cause dynamically a voltage drop at V_{CC2} . Often some power supplies are not able to follow the fast current rise time. In that case another 4.7 μF (type, see table under C1) at V_{CC2} will be helpful.

Under extreme EMI conditions as placing an RF-transmitter antenna on top of the transceiver, we recommend to protect all inputs by a low-pass filter, as a minimum a 12 pF capacitor, especially at the RXD port. The transceiver itself withstands EMI at GSM frequencies above 500 V/m. When interference is observed, the wiring to the inputs picks it up. It is verified by DPI measurements that as long as the interfering RF - voltage is below the logic threshold levels of the inputs and equivalent levels at the outputs no interferences are expected.

One should keep in mind that basic RF - design rules for circuit design should be taken into account. Especially longer signal lines should not be used without termination. See e.g. "The Art of Electronics" Paul Horowitz, Winfield Hill, 1989, Cambridge University Press, ISBN: 0521370957.

Table 1.
Recommended Tests and Application Circuit Components

| Component | Recommended value | Vishay part number |
|-----------|--|----------------------|
| C1 | 4.7 μF , 16 V | 293D 475X9 016B |
| C2 | 0.1 μF , Ceramic | VJ 1206 Y 104 J XXMT |
| R1 | depends on current to be adjusted, e. g. with $V_{CC2} = 3.3 \text{ V}$ 56 Ω is an option for minimum low power operation | |
| R2 | 47 Ω , 0.125 W | CRCW-1206-47R0-F-RT1 |

Figure 2 shows an example of a typical application with a separate supply voltage V_S and using the transceiver with the IRED Anode connected to the unregulated battery V_{batt} . This method reduces the peak load of the regulated power supply and saves therefore costs. Alternatively all supplies can also be tied to only one voltage source. R1 and C1 are not used in this case and are depending on the circuit design in most cases not necessary.

In figure 2 an option is shown to operate the transmitter at two different power levels to switch for long range to low power mode for e.g. saving power for IrDA application but use the full range specification for remote control. The additional components are marked in the figure.

For operating at RS232 ports TOIM4232 is recommended as ENDEC.

I/O and Software

In the description, already different I/Os are mentioned. Different combinations are tested and the function verified with the special drivers available from the I/O suppliers. In special cases refer to the I/O manual, the Vishay application notes, or contact directly Vishay Sales, Marketing or Application.

Current Derating Diagram

Figure 3 shows the maximum operating temperature when the device is operated without external current limiting resistor.

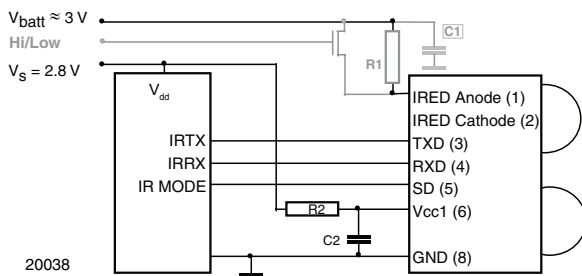

Figure 2. Typical Application Circuit. Grey: Optional for Hi/Low Switching.

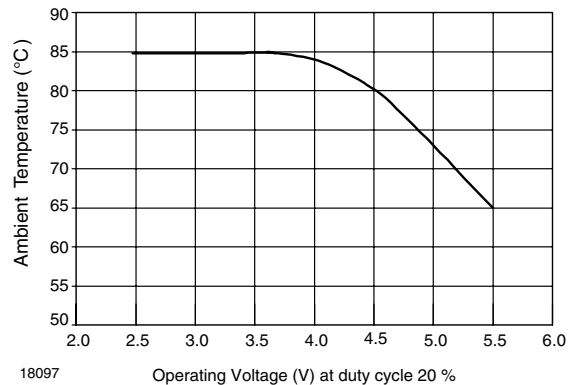

Figure 3. Current Derating Diagram

Table 2. Truth table

| Inputs | | | Outputs | | Remark |
|----------------|--------------|--|---|----------------|--|
| SD | TXD | Optical input Irradiance mW/m ² | RXD | Transmitter | Operation |
| high > 1 ms | x | x | weakly pulled (500 kΩ) to V _{CC1} | 0 | Shutdown |
| low | high < 50 μs | x | low active | I _e | Transmitting |
| | high > 50 μs | x | high inactive | 0 | Protection is active |
| | low | < 4 | high inactive | 0 | Ignoring low signals below the IrDA defined threshold for noise immunity |
| | low | > Min. irradiance E _e < Max. irradiance E _e | low (active) | 0 | Response to an IrDA compliant optical input signal |
| | low | > Max. irradiance E _e | undefined | 0 | Overload conditions can cause unexpected outputs |

Recommended Solder Profiles

Solder Profile for Sn/Pb Soldering

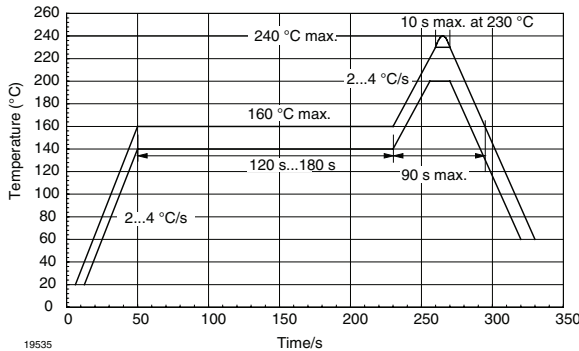

Figure 4. Recommended Solder Profile for Sn/Pb Soldering

Lead (Pb)-Free, Recommended Solder Profile

The TFDU4101 is a lead (Pb)-free transceiver and qualified for lead (Pb)-free processing. For lead (Pb)-free solder paste like Sn (3.0 - 4.0) Ag (0.5 - 0.9) Cu, there are two standard reflow profiles: Ramp-Soak-Spike (RSS) and Ramp-To-Spike (RTS). The Ramp-Soak-Spike profile was developed primarily for reflow ovens heated by infrared radiation. With widespread use of forced convection reflow ovens the Ramp-To-Spike profile is used increasingly. Shown below in figure 5 and 6 are VISHAY's recommended profiles for use with the TFDU4101 transceivers. For more details please refer to the application note "SMD Assembly Instructions" (<http://www.vishay.com/docs/82602/82602.pdf>).

A ramp-up rate less than 0.9 °C/s is not recommended. Ramp-up rates faster than 1.3 °C/s could damage an optical part because the thermal conductivity is less than compared to a standard IC.

Wave Soldering

For TFDUxxxx and TFBSxxxx transceiver devices wave soldering is not recommended.

Manual Soldering

Manual soldering is the standard method for lab use. However, for a production process it cannot be recommended because the risk of damage is highly dependent on the experience of the operator. Nevertheless, we added a chapter to the above mentioned application note, describing manual soldering and desoldering.

Storage

The storage and drying processes for all VISHAY transceivers (TFDUxxxx and TFBSxxx) are equivalent to MSL4.

The data for the drying procedure is given on labels on the packing and also in the application note "Taping, Labeling, Storage and Packing" (<http://www.vishay.com/docs/82601/82601.pdf>).

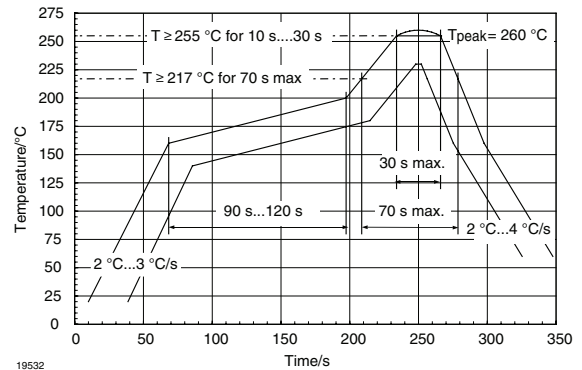

Figure 5. Solder Profile, RSS Recommendation

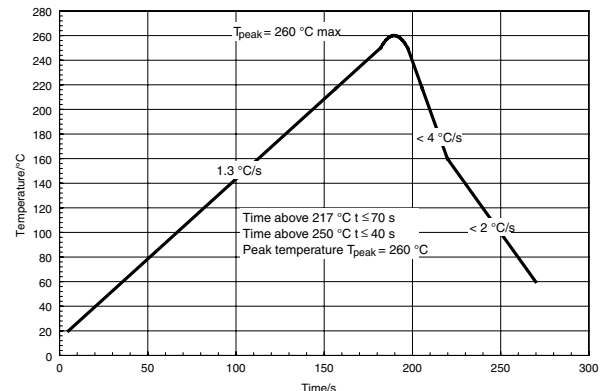

Figure 6. RTS Recommendation

Package Dimensions in mm

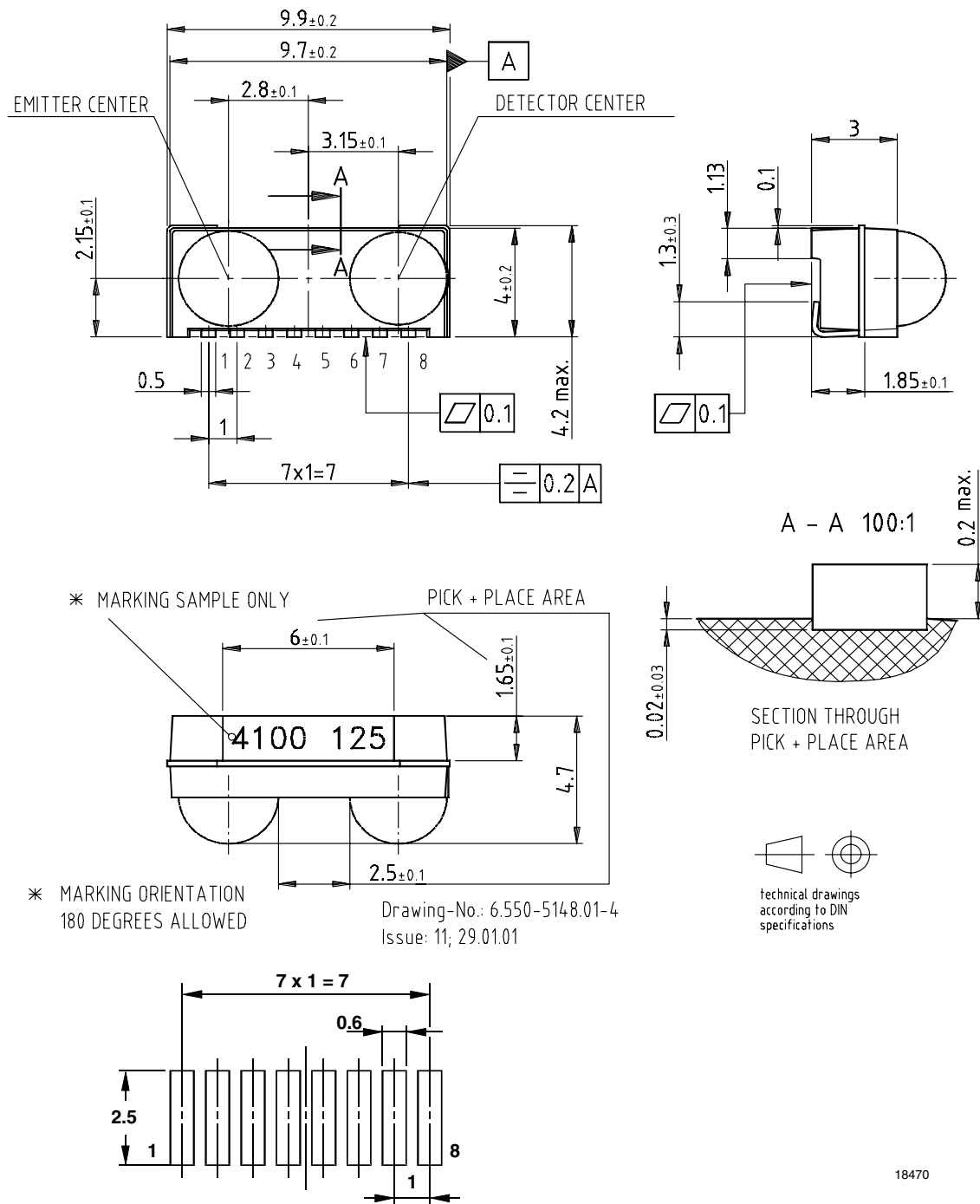

Figure 7. Package Drawing TFDU6103, Tolerance ± 0.2 mm if not otherwise mentioned

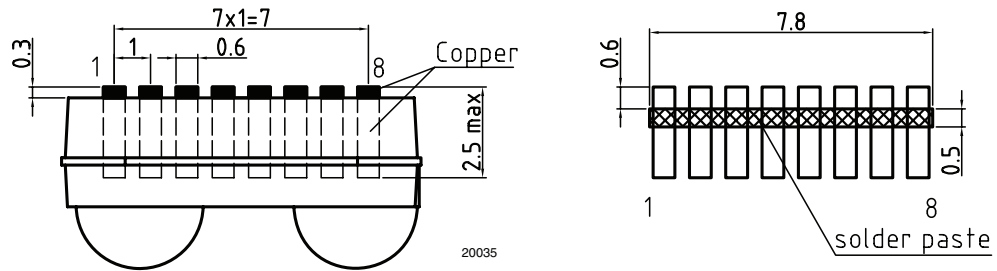

Figure 8. Recommended Footprint for Side View Applications and Solderpaste Mask

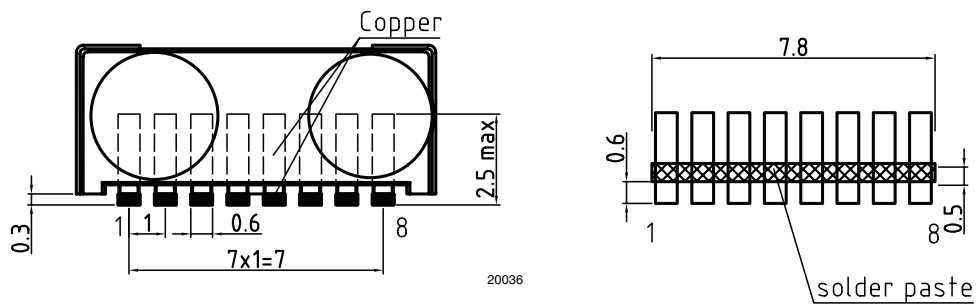
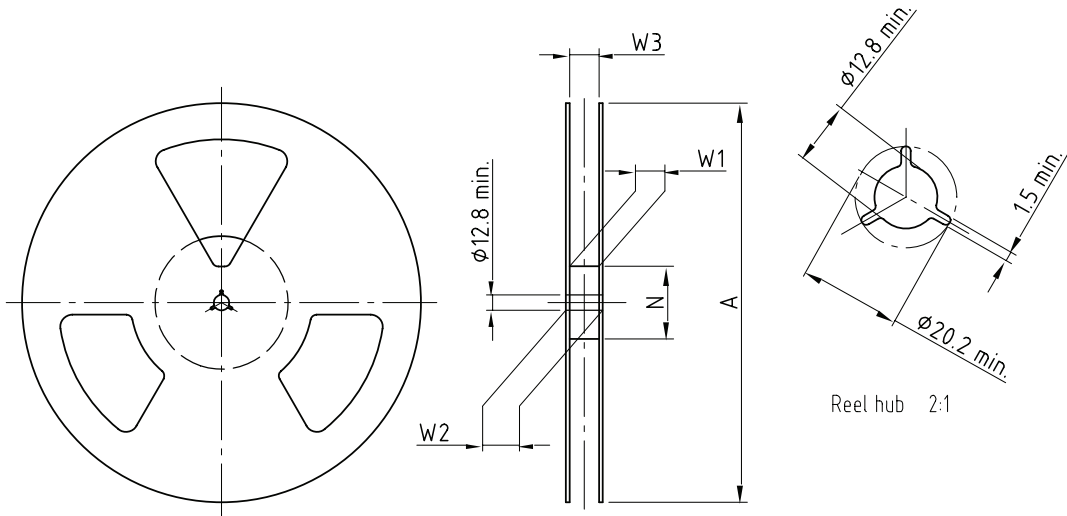

Figure 9. Recommended Footprint for Top View Applications and Solderpaste Mask

Reel Dimensions in mm



Drawing-No.: 9.800-5090.01-4
 Issue: 1; 29.11.05
 14017

Form of the leave open
 of the wheel is supplier specific.

Dimension acc. to IEC EN 60 286-3

technical drawings
 according to DIN
 specifications

Reel hub 2:1

| Tape width | A max. | N | W_1 min. | W_2 max. | W_3 min. | W_3 max. |
|------------|--------|----|------------|------------|------------|------------|
| mm | mm | mm | mm | mm | mm | mm |
| 24 | 330 | 60 | 24.4 | 30.4 | 23.9 | 27.4 |

Tape Dimensions in mm

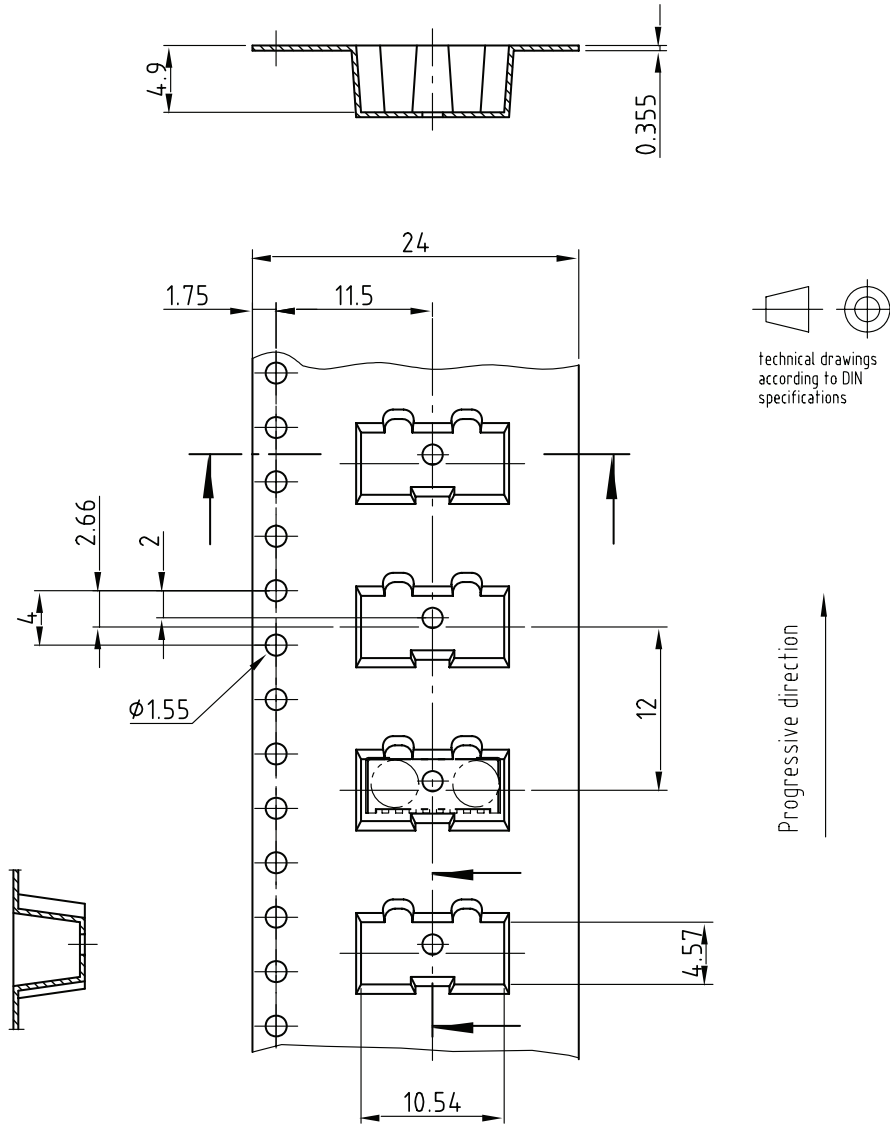

Drawing-No.: 9.700-5251.01-4
Issue: 3; 02.09.05
19824

Figure 10. Tape Drawing, TFDU6103 for Top View Mounting, Tolerance ± 0.1 mm

Tape Dimensions in mm

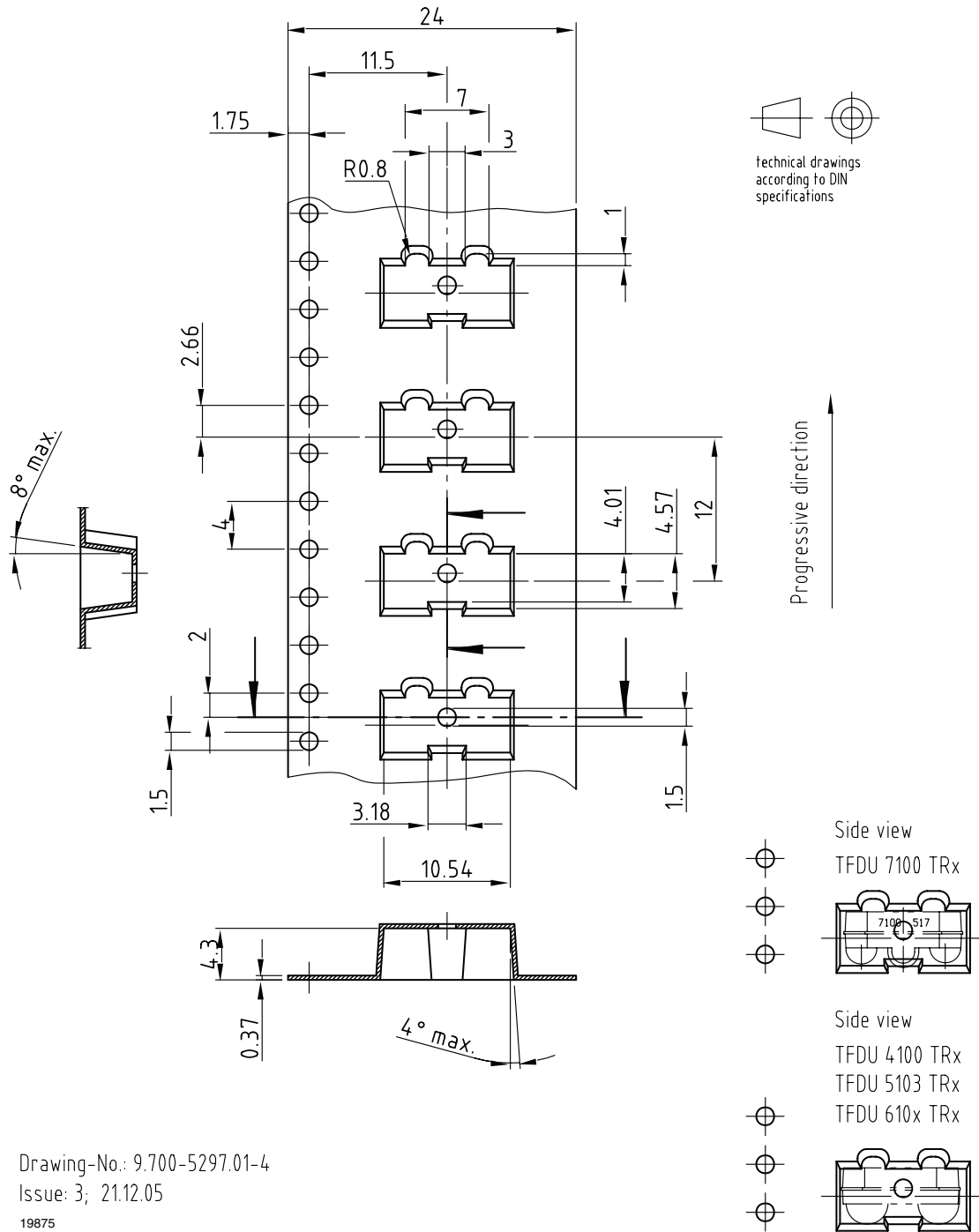

Drawing-No.: 9.700-5297.01-4
 Issue: 3; 21.12.05
 19875

Figure 11. Tape Drawing, TFDU6103 for Side View Mounting, Tolerance ± 0.1 mm



Ozone Depleting Substances Policy Statement

It is the policy of Vishay Semiconductor GmbH to

1. Meet all present and future national and international statutory requirements.
2. Regularly and continuously improve the performance of our products, processes, distribution and operating systems with respect to their impact on the health and safety of our employees and the public, as well as their impact on the environment.

It is particular concern to control or eliminate releases of those substances into the atmosphere which are known as ozone depleting substances (ODSs).

The Montreal Protocol (1987) and its London Amendments (1990) intend to severely restrict the use of ODSs and forbid their use within the next ten years. Various national and international initiatives are pressing for an earlier ban on these substances.

Vishay Semiconductor GmbH has been able to use its policy of continuous improvements to eliminate the use of ODSs listed in the following documents.

1. Annex A, B and list of transitional substances of the Montreal Protocol and the London Amendments respectively
2. Class I and II ozone depleting substances in the Clean Air Act Amendments of 1990 by the Environmental Protection Agency (EPA) in the USA
3. Council Decision 88/540/EEC and 91/690/EEC Annex A, B and C (transitional substances) respectively.

Vishay Semiconductor GmbH can certify that our semiconductors are not manufactured with ozone depleting substances and do not contain such substances.

We reserve the right to make changes to improve technical design
and may do so without further notice.

Parameters can vary in different applications. All operating parameters must be validated for each customer application by the customer. Should the buyer use Vishay Semiconductors products for any unintended or unauthorized application, the buyer shall indemnify Vishay Semiconductors against all claims, costs, damages, and expenses, arising out of, directly or indirectly, any claim of personal damage, injury or death associated with such unintended or unauthorized use.

Vishay Semiconductor GmbH, P.O.B. 3535, D-74025 Heilbronn, Germany



Disclaimer

All product specifications and data are subject to change without notice.

Vishay Intertechnology, Inc., its affiliates, agents, and employees, and all persons acting on its or their behalf (collectively, "Vishay"), disclaim any and all liability for any errors, inaccuracies or incompleteness contained herein or in any other disclosure relating to any product.

Vishay disclaims any and all liability arising out of the use or application of any product described herein or of any information provided herein to the maximum extent permitted by law. The product specifications do not expand or otherwise modify Vishay's terms and conditions of purchase, including but not limited to the warranty expressed therein, which apply to these products.

No license, express or implied, by estoppel or otherwise, to any intellectual property rights is granted by this document or by any conduct of Vishay.

The products shown herein are not designed for use in medical, life-saving, or life-sustaining applications unless otherwise expressly indicated. Customers using or selling Vishay products not expressly indicated for use in such applications do so entirely at their own risk and agree to fully indemnify Vishay for any damages arising or resulting from such use or sale. Please contact authorized Vishay personnel to obtain written terms and conditions regarding products designed for such applications.

Product names and markings noted herein may be trademarks of their respective owners.